

Surelight Wire Assembly Instructions

1.0 Recommended Tools for Assembling Surelight Wires:-

- Wire-Stripper
- Cutter
- Flat nose pliers
- Soldering iron (up to 30Watts).
- Heatgun or Blow Torch
- Heat Shrink Tubing 3.2mmØ
- Heat Shrink Tubing 4.8mmØ

Please note. Do not connect directly to mains supply - an inverter is essential when using Surelight Wires.

Surelight Wire Connection to Electrical Cable

Diagram to show Connecting Surelight Wire to Electrical Cable

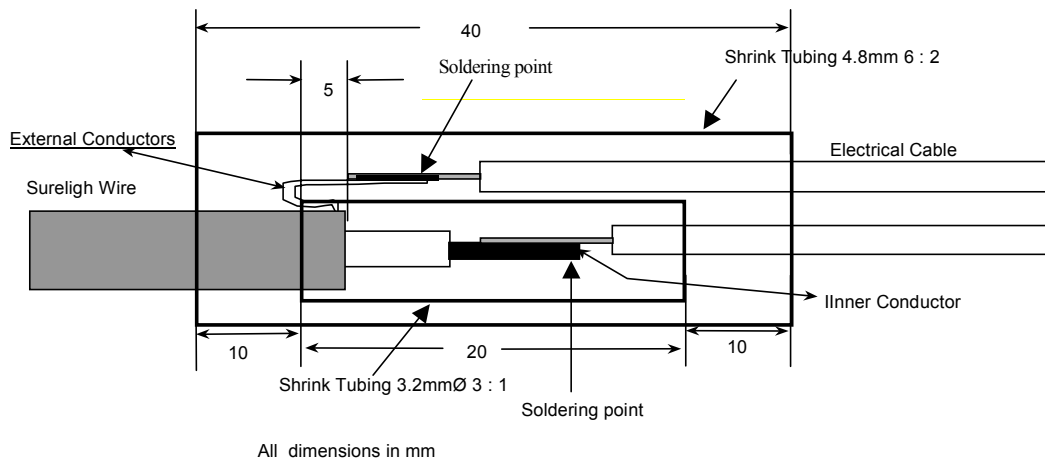

Step 1:

Strip 20 - 30mm of outer and inner insulation layers of the Surelight Wire.

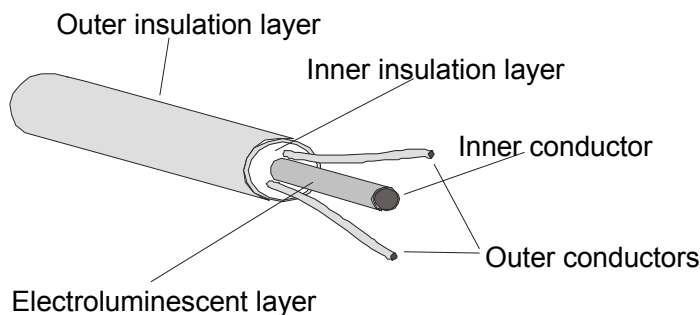

Step 2:

Slide a piece of 3.2mmØ shrink tubing over the electrical cable wires

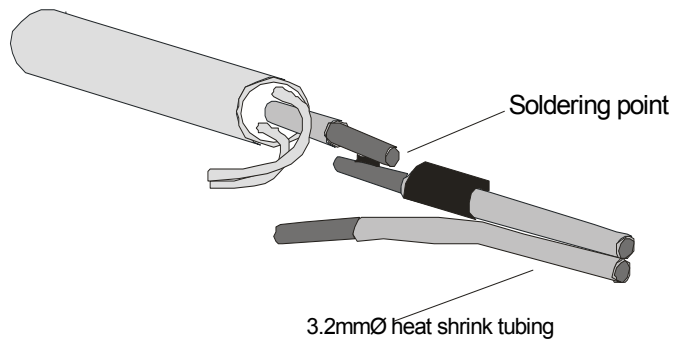

Step 3:

Solder the inner conductor/core of the Surelight Wire to the electrical cable.

Attention

Soldering of the Surelight Wire should be done with minimal use of FLUX or other chemicals. If, required - use very little FLUX and prevent the FLUX from getting in touch with the Surelight Wire's coating layers. It may damage the wires internal layers. Standard core fluxed wire solders are preferred for making the joints.

Slide the 3.2mmØ shrink tubing over the soldered connection and with the aid of a heatgun shrink the tubing.

The result should look like the following picture:

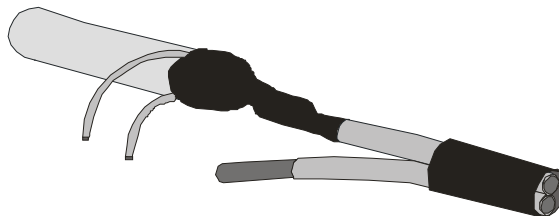

Step 4:

Join and twist the two thin outer conductors.

Solder the other lead of the electrical cable to the outer connector of the Surelight Wire.

Be careful Do not detach them - as they are delicate.

Slide a piece of 4.8mmØ shrink tubing over the electrical cable.

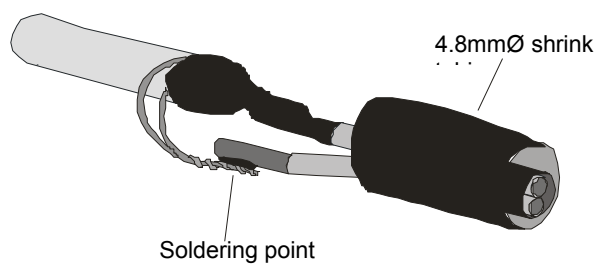

Step 5:

Slide the 4.8mmØ shrink tubing over the connection and with the aid of the heatgun shrink the tubing on top of the connection.

End product should look as follows:

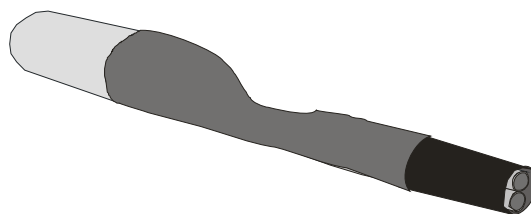

Connecting Segments of Surelight Wires

Step 1:

Strip approx 20mm of outer and inner insulation layers of the two Surelight Wires.

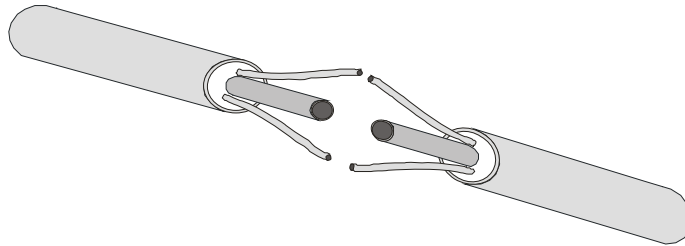

Step 2:

Slide a piece of 3.2mmØ shrink tubing over the inner conductor of the right Surelight Wire.

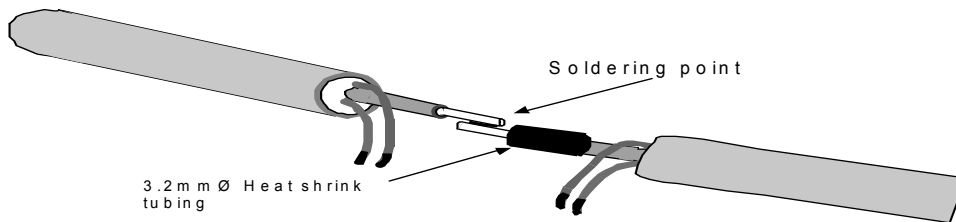

Step 3:

Solder the inner conductors of the two Surelight Wire.

Attention

Soldering of the Surelight Wire should be done with minimal use of FLUX or other chemicals.

If, required - use very little flux and prevent the flux from getting in touch with the wire's coating layers.

It may damage the wires internal layers. Standard core fluxed wire solders are preferred for making the joints.

Slide the 3.2mm shrink tubing over the soldered connection and with the aid of a heatgun shrink the tubing.

The result should look like the following picture:

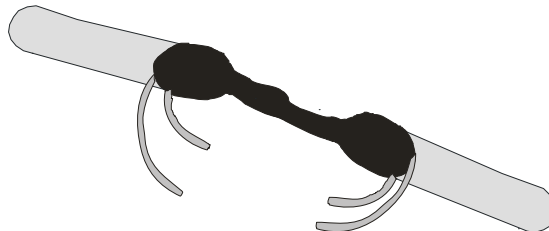

Step 4:

Join and twist the two thin outer conductors of the two Surelight Wires and solder them.

Be careful Do not detach them - as they are delicate.

Slide a piece of 4.8mmØ shrink tubing over the right Surelight Wire.

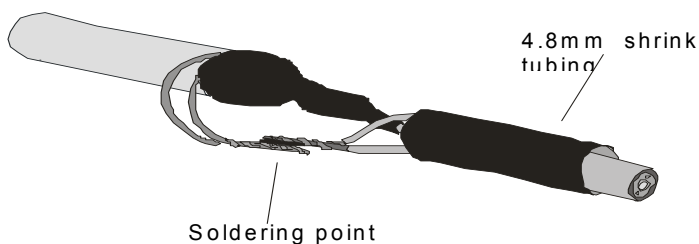

Step 5:

Slide the 4.8mm heat-shrink tubing over the connection and with the aid of the heatgun; shrink the tubing on top of the connection.

End product should look as follows:

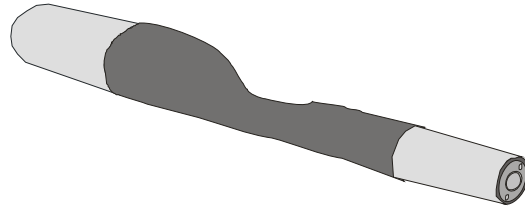

Recommended Components:
Heat Shrink Tubing 3.2mmØ
Heat Shrink Tubing 4.8mmØ

Surelight Wire Termination

Step 1:

Strip 5 to 10mm end off outer and inner insulation layers of the Surelight Wire.

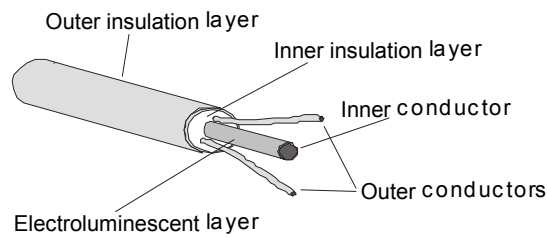

Step 2:

Peel back outer conductors and cut them off at the outer insulation step. Take a 3.2mm shrink tubing and place it over stripped end of the Surelight Wire.

Step 3:

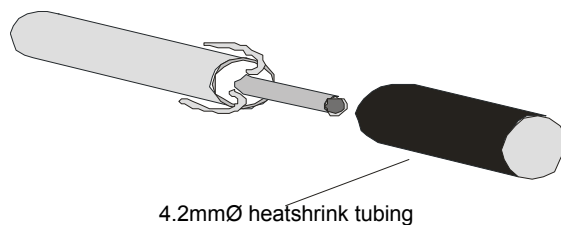

Use a heat gun to shrink the tubing. Leave a clearance of 10mm of shrink tubing over the edge of Surelight Wire. Seal it tight with pliers.

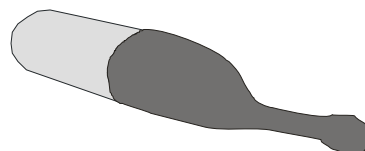

End product should look as follows:

